

I-8D ELECTRICAL SCHEMATIC

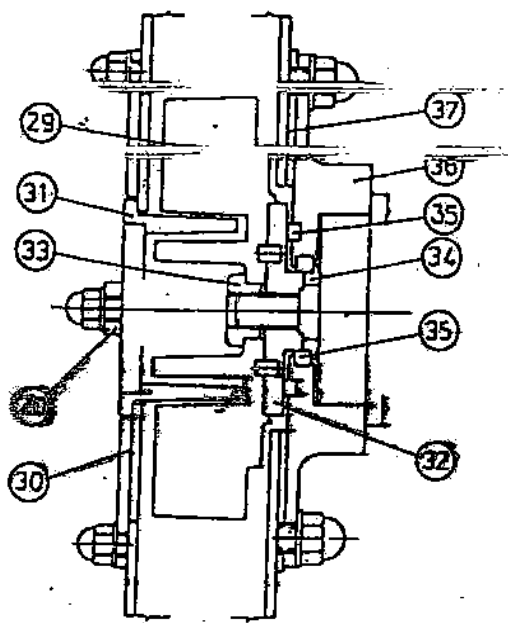

Detail X

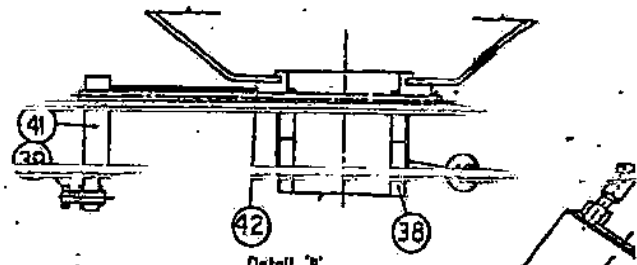

Detail B

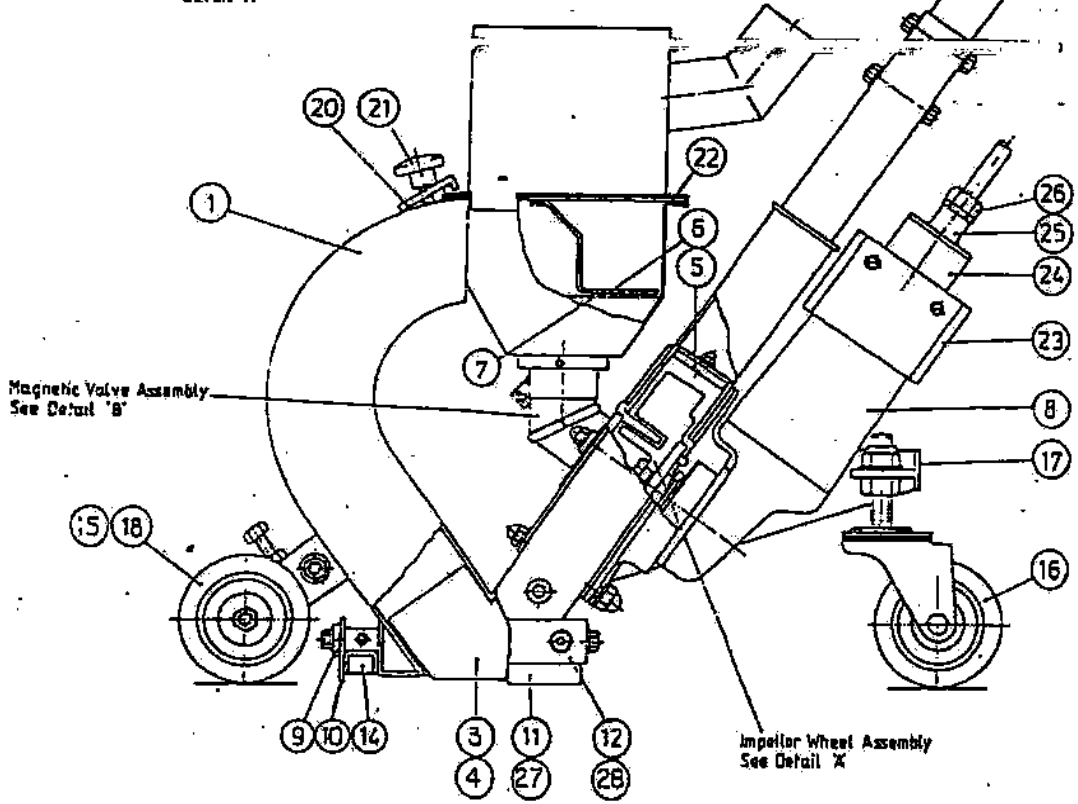

Magnetic Valve Assembly
See Detail B

Impeller Wheel Assembly
See Detail X

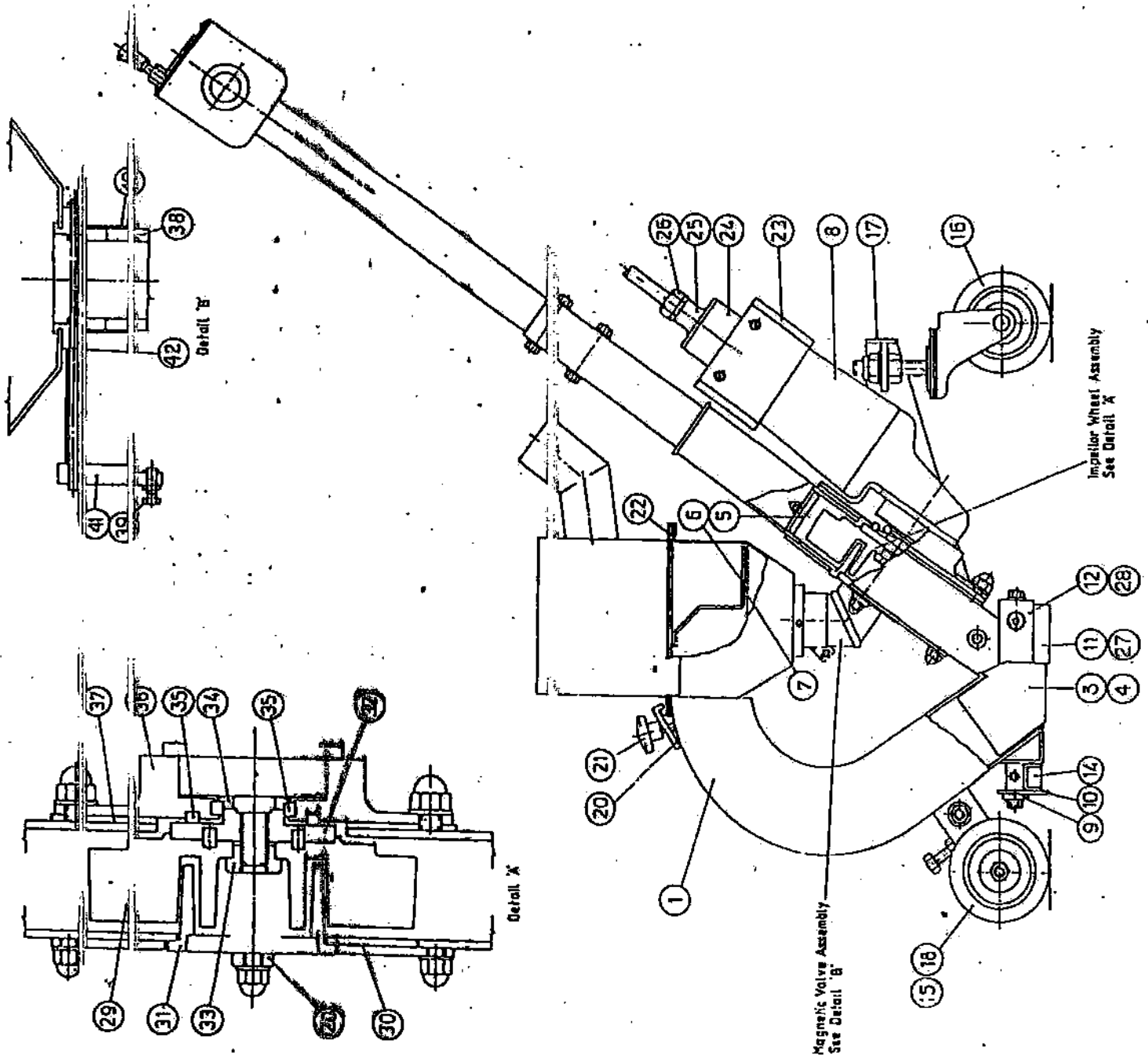
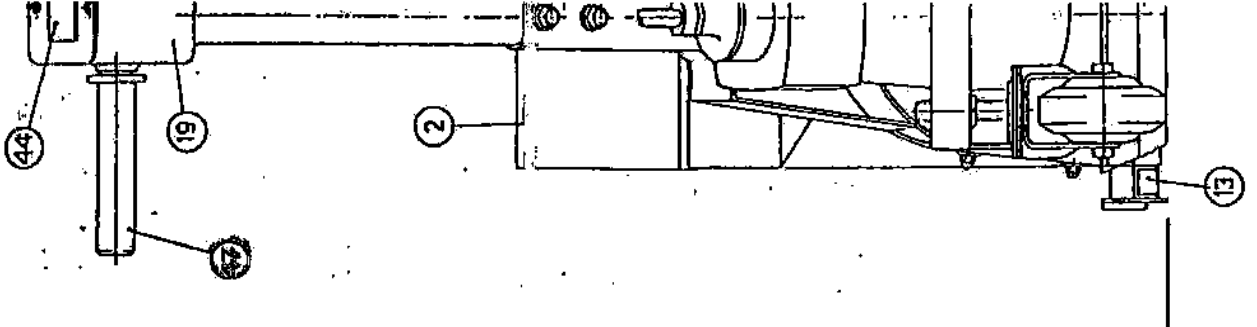

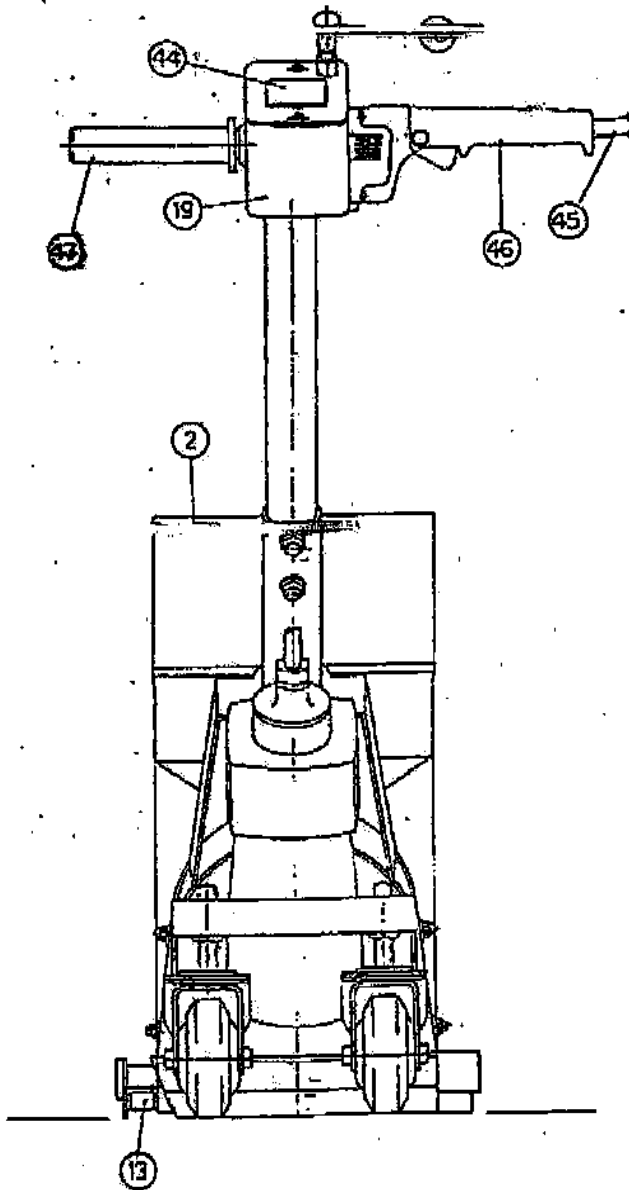

1 - 80 Mark IV Parts List

Item	Description	Part #	Qty.
1	Blast Housing		1
2	Storage Hopper		1
3	Motor		1
4	Right - Side Liner	497306	1
5	Top Liner	497307	1
6	Deflector Plate	968213	1
7	Mesh Screen	979042	1
8	Motor	970103	1
9	Front / Rear Retainer	681153	2
10	Front / Rear Skirt	681152	2
11	Side Skirt	681155	2
12	Side Retainer	681154	2
13	Side Magnet	969780	2
14	Front Magnet	969753	1
15	Front Wheel	675354	2
16	Rear Castor	675356	2
17	Wheel Support		1
18	Wheel Axle and Support		1
19	Control Console	969980	1
20	Control Cage Clamp	970012	3
21	Clamp Knob	975615	1
22	Seal - Storage Hopper	972161	1
23	Motor End Bracket	974797	1
24	Ring Extension (25 mm)	975621	1
25	Dome (20 mm)	975616	1
26	Card Grip	692471	1
27	Trim Seal	681156	1
28	Trim Plate	681157	1
29	Blast Wheel	459556	1
30	Control Cage Bracket	976324	1
31	Control Cage	451476	1
32	Hub	497312	1
33	Wheel Nut	497311	1
34	Motor Shaft Shield	690928	1
35	Felt Seal	960855	2
36	Motor Mounting Plate	971867	1
37	Seal - Motor Mounting Plate	497310	1
38	Feed Spout	967577	1
39	Nipple and Nut	691612	1
40	Feed Spout Sealing Ring	684912	1
41	Valve Lever	969756	1
42	Abrasive Valve Assembly	969819	1
43	Abrasive Control Cable	975619	1
44	Ammeter	975617	1
45	Electric Cable (3 cond, 14 ga.)	276995	20 ft.
46	Switch Handle	975620	1
47	Handle Grip	453290	1

*Use Wheel Kit Part # 678823. The kit contains items 29, 31 and 33. (Part #s - 459556, 451476 and 497311.)

DIMENSIONAL TOLERANCES - UNLESS OTHERWISE NOTED - INSPECTION SPECIFICATION - WIL 1007				1-80	80
FINISHING	WELDING	WELDING AND ASSEMBLY	MATERIAL	CASTING	
(TURNING, DRILLING, REAMING) FINISH DIMENSIONS .0005 (SEE INSTRUCTIONS)	FINISH DIMENSIONS .0010 (SEE INSTRUCTIONS)	FINISH DIMENSIONS .0005 (SEE INSTRUCTIONS)	FLATNESS IN AVERAGES .0008 LEADER THROUGH HOLE	CAST PARTS SHALL BE OF STEEL UNLESS OTHERWISE SPECIFIED FINISHING TO BE BY THE CUSTOMER DIMENSIONS OF 1/8 INCH TO 1/2 INCH SHALL BE TO UNLESS OTHERWISE SPECIFIED (P)	
ANGULAR DIMENSIONS 1/2°-20°	ANGULAR DIMENSIONS 1/2°-20°	ANGULAR DIMENSIONS 1/2°-20°	ANGULAR DIMENSIONS TO SURFACE SHALL BE UNLESS OTHERWISE SPECIFIED	TOLERANCES UNLESS OTHERWISE SPECIFIED	
ANGULAR DIMENSIONS 1/2°-20° (WELD JOINTS)	ANGULAR 1/2°-20°	ALL WELDS SHALL BE .005			
NOTE: DIMENSIONS ARE TO UNLESS OTHERWISE SPECIFIED			THE DIMENSIONS AND THE DESIGN ARE THE PROPERTY OF WHEELABRATOR CORPORATION AND ARE TO BE KEPT IN CONFIDENCE AND NOT TO BE REPRODUCED		
			None TAY 4/20/95 1-1 95D382		

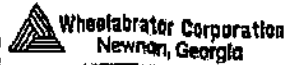

1-80 Mark IV Machine Assembly

95D382